

 **PT. BADAQ PRIMA LESTARI**

Kawasan Industri Millenium, Jl. Millenium 15 Blok I-2 No. 3A,

Desa Peusar, Kecamatan Panongan,

Kabupaten Tangerang, Banten 15710 INDONESIA

Tel: +62 59986616 / 30 , Fax.: +62 59986847

E-mail: sales@badakprima.co.id

www.badakprima.co.id



TOYO

ICE301/ICE351

Electric Counterbalance Forklift Truck 3.0/3.5T

- Lithium-ion technology
- Low TCO
- Easy driving
- Brilliant visibility
- Telematics

PRODUCT FEATURES

■ Lithium-ion technology

ICE 301/ICE 351 adapts LFP Li-ion battery that prevents the battery from self-ignition and ensures safety operation. ICE 301/ICE 351 supports opportunity charging so it can be charged at preferable time during the day without disrupting working schedules.

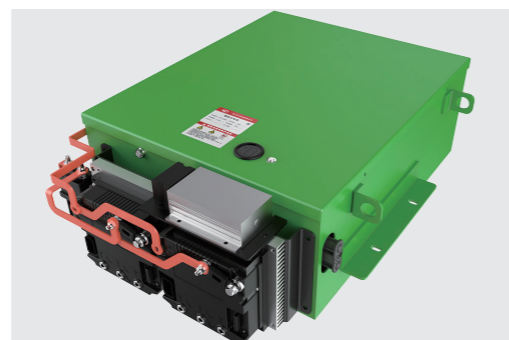

■ Low TCO

Comparing to a diesel forklift truck, ICE 301/ICE 351 saves 30%-50% of energy cost with li-ion technology. And there is no maintenance fee with no air filter, oil filter, engine oil or starter battery installed on the truck.

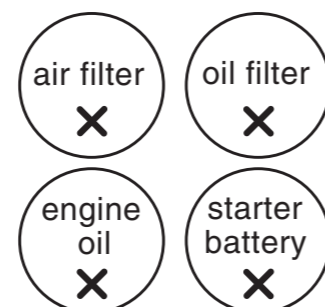

■ Easy driving

The truck is equipped with mechanical braking system. The system shortens the braking distance to ensure safety while reducing the driving fatigue in the meantime.



■ Brilliant visibility

A wide view mast ensures good visibility during operation. This enables operator to better monitor the status of the cargo.



■ Telematics

ICE 301/ICE 351 offers EP' s latest Telematics. It provides the following features to facilitate your fleet management:

- Truck location in real-time
- Reports of truck usages and diagnosis
- Li-ion battery condition analytics
- Updates on card access registration



PRODUCT PARAMETERS

			TOYO		TOYO	
			ICE301	ICE351		
Distinguishing mark	1.1	Manufacturer			TOYO	TOYO
	1.2	Model designation			ICE301	ICE351
	1.3	Drive			Electric	Electric
	1.4	Operator type			Seated	Seated
	1.5	Load capacity	Q	kg	3000	3500
	1.6	Load center distance	c	mm	500	500
	1.8	Load distance, centre of drive axle to fork	x	mm	481	481
	1.9	Wheelbase	y	mm	1750	1810
	Service weight	2.1	Service weight			4080
2.2		Axle loading, laden front/rear			6420/660	7100/960
2.3		Axle loading, unladen front/rear			1740/2340	1670/2890
Tyres/chassis	3.1	Tyre type			Pneumatic	Pneumatic
	3.2	Tyre size, front			28X9-15-14PR	28X9-15-14PR
	3.3	Tyre size, rear			6.50-10-10PR	6.50-10-10PR
	3.5	Wheels, number front/rear (x=drive wheels)			2x/2	2x/2
	3.6	Tread width, front	b10	mm	1010	1010
	3.7	Tread width, rear	b11	mm	980	980
Dimensions	4.1	Tilt of mast/fork carriage forward/backward	α/β	°	6/10	6/10
	4.2	Retracted mast height	h1	mm	2070	2070
	4.3	Free lift	h2	mm	120	120
	4.4	Lift height	h3	mm	3000	3000
	4.5	Height, mast extended	h4	mm	4110	4110
	4.7	Height of overhead guard (cabin)	h6	mm	2160	2190
	4.8	Seat height/standing height	h7	mm	1130	1130
	4.12	Tow coupling height	h10	mm	320	320
	4.19	Overall length	l1	mm	3780	3940
	4.20	Length to face of forks	l2	mm	2710	2870
	4.21	Overall width	b1/b2	mm	1230	1230
	4.22	Fork dimensions	s/e/l	mm	45×125×1070	50×125×1070
	4.23	A,B Fork carriage class/type A, B			3A	3A
	4.24	Fork carriage width	b3	mm	1150	1150
	Performance data	4.31	Ground clearance, laden, below mast	m1	mm	120
4.32		Ground clearance, center of wheelbase	m2	mm	150	150
4.34.1		Aisle width for pallets 1000×1200 crossways	Ast	mm	4181	4326
4.34.2		Aisle width for pallets 800×1200 crossways	Ast	mm	4381	4526
4.35		Turning radius	Wa	mm	2500	2645
5.1		Travel speed, laden/unladen		km/h	11/12	11/12
5.2		Lifting speed, laden/unladen		m/s	0.29/0.36	0.26/0.34
Electric-engine	5.3	Lowering speed, laden/unladen		m/s	0.4/0.43	0.4/0.43
	5.5	Drawbar pull, laden/unladen		N	—	—
	5.6	Max. drawbar pull, laden/unladen		N	—	—
	5.8	Max. gradeability, laden/unladen		%	15/15	15/15
	5.10	Service brake			Hydraulic	Hydraulic
	5.11	Parking brake			Mechanical	Mechanical
	6.1	Drive motor rating S2 60 min		kW	10	10
	6.2	Lift motor rating at S3 15%		kW	12	12
Addition data	6.4	Battery voltage/nominal capacity		V/Ah	80/205	80/280
	6.5	Battery weight		kg	—	—
	8.1	Type of drive control			AC	AC
	10.5	Steering design			Hydraulic	Hydraulic
10.7	Sound pressure level at the driver's ear		dB(A)	< 74	< 74	

MAST OPTION

Mast types	Lift height (h3)	Height, Mast		Height, Free lift(h2)		
		Height, mast lowered(h1)	Height, mast extended(h4)		No shelving	With shelving
			No shelving	With shelving		
		mm	mm	mm	mm	
2-Standard Mast	2700	1920	3270	3810	120	120
	3000	2070	3570	4110	120	120
	3300	2220	3690	4410	120	120
	3500	2320	3890	4610	120	120
	3600	2370	3990	4710	120	120
	4000	2620	4040	5110	120	120
	4300	2770	4340	5410	120	120
	4500	2870	4290	5610	120	120
2-Free Mast	2500	1805	2220	3610	1210	560
	2700	1905	2320	3810	1310	660
	3000	2055	2620	4110	1460	810
	3300	2205	3870	4410	1610	960
	3600	2355	4020	4710	1760	1110
3-Free Mast	4300	2095	4910	5410	1360	730
	4500	2175	5070	5610	1460	810
	4800	2280	5375	5910	1565	915
	5000	2365	5570	6110	1610	960
	5500	2615	6150	6610	1770	1120
	6000	2865	6570	7110	2020	1370

LINE GRAPH

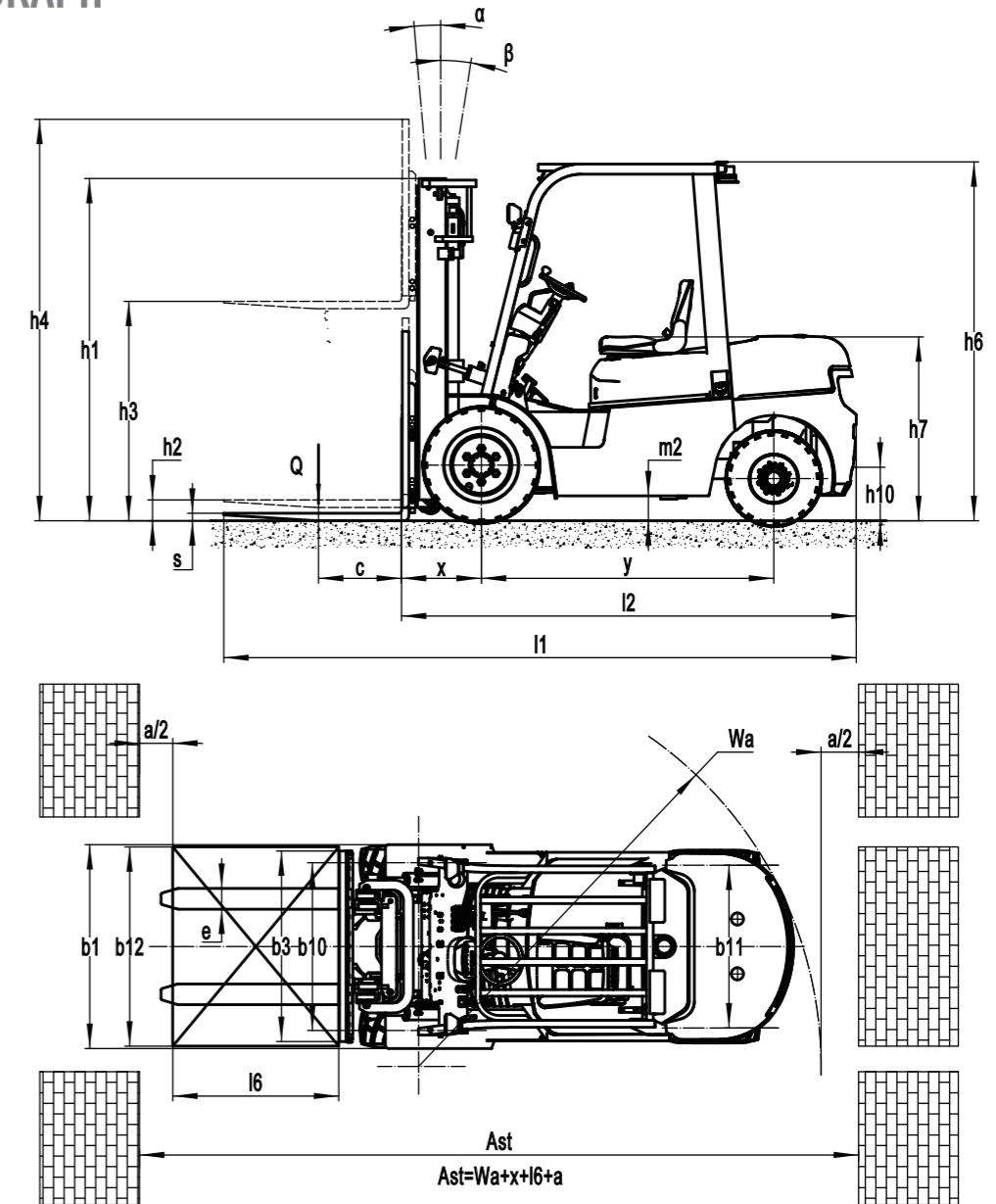

OPTION

No.	Optional items	ICE301	ICE351
1	Fork length	●1070○customization consultation	●1070○customization consultation
2	Attachments	●NA○integrated side shifter○external side shifter ○ customization consultation	●NA○integrated side shifter○external side shifter ○ customization consultation
3	Overhead guard	●normal overhead guard ○customization consultation	●normal overhead guard ○customization consultation
4	Front wheel configuration	●single○dual	●single○dual
5	Tyre type	●pneumatic○Solid rubber tyre ○Environmental solid tyre	●pneumatic○Solid rubber tyre ○Environmental solid tyre
6	Front light	●Front light○LED front light	●Front light○LED front light
7	Auxiliary light	●NA○Back light	●NA○Back light
8	Safety components	●NA○Fire extinguisher○blue light	●NA○Fire extinguisher○blue light
9	Seat	●normal seat○suspension seat	●normal seat○suspension seat
10	Cockpit	●NA○Cockpit○With fan heater○With front windshield wiper○With rear windshield wiper	●NA○Cockpit○With fan heater○With front windshield wiper○With rear windshield wiper
11	Rearview	●single○dual	●single○dual
12	Air fan	●NA○single	●NA○single
13	Charging	●80V65A○80V130A○80V200A○80V60A (integrated)	●80V65A○80V130A○80V200A○80V60A (integrated)
14	Li-Ion battery	●80V205Ah○80V280Ah○80V410Ah	●80V280Ah○80V410Ah

Note: ● standard ○ option — NA

RATED CAPACITY

